

Solent & Pratt Double Block & Bleed TOSV

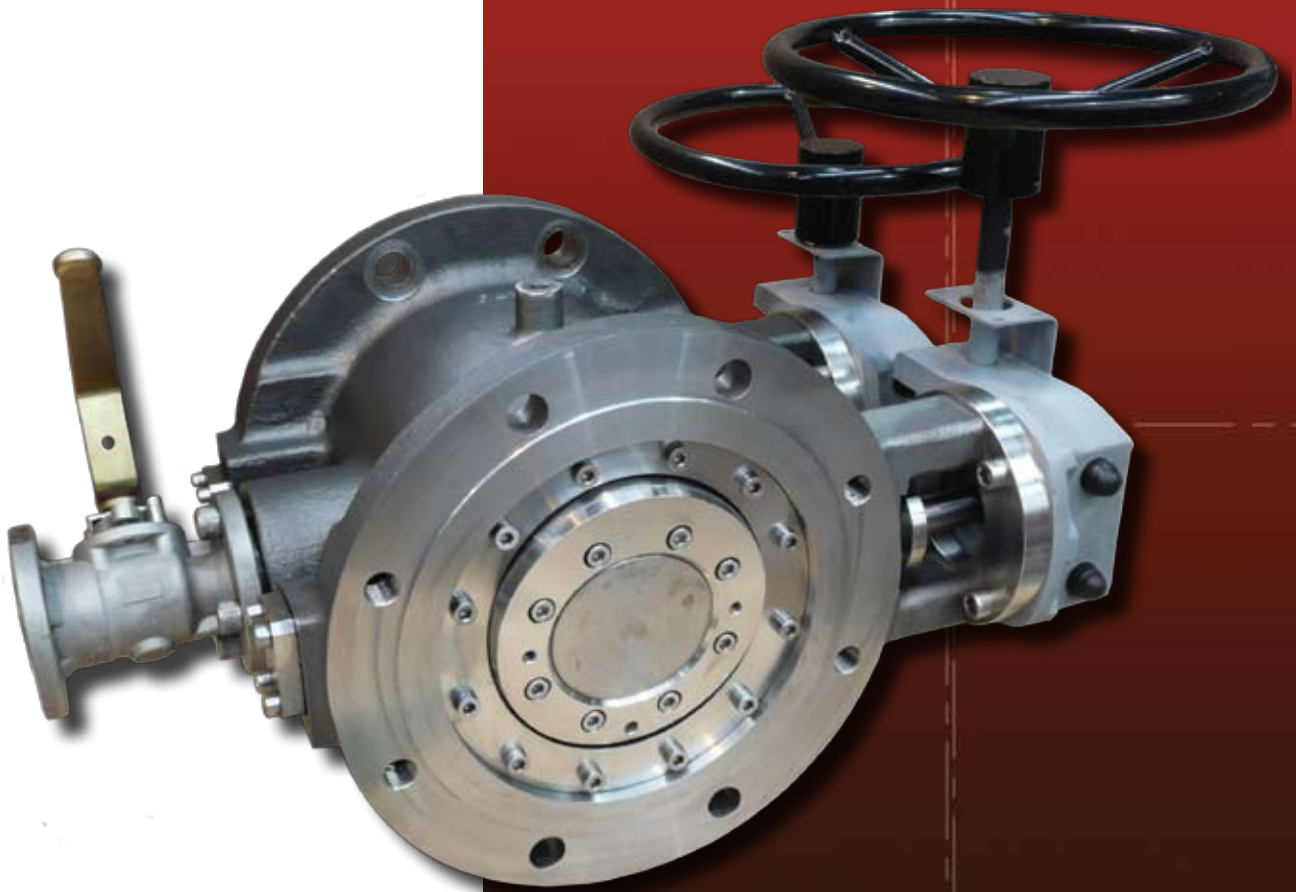

Double Block & Bleed

Over recent years the need to increased safety with regard to both operatives & the environment Solent & Pratt have pushed the design of the Triple Offset butterfly valve with all its benefits and developed two types of “Double Block & Bleed” (DBB) valves that can be utilized for many applications. The Single Disc & Twin Disc design have all the inherent features of the standard TOSV with the added benefit of a bleed cavity that can be used to provide a safe working environment downstream of the valve when used on the isolation of toxic, explosive or other critical applications. The use of the TOSV butterfly valve gives an inherently firesafe metal to metal seated valve with zero leakage capability for use on the most demanding applications.

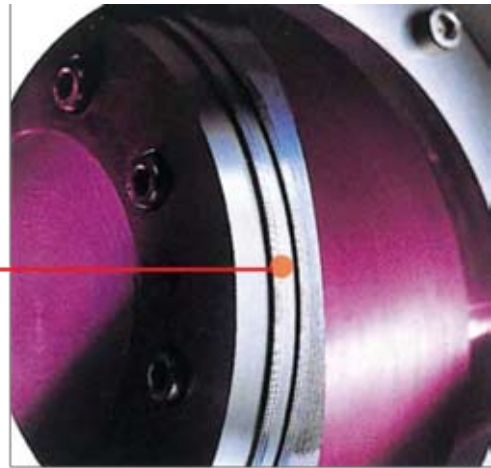

New design provides a high integrity double seal with bleed facility between

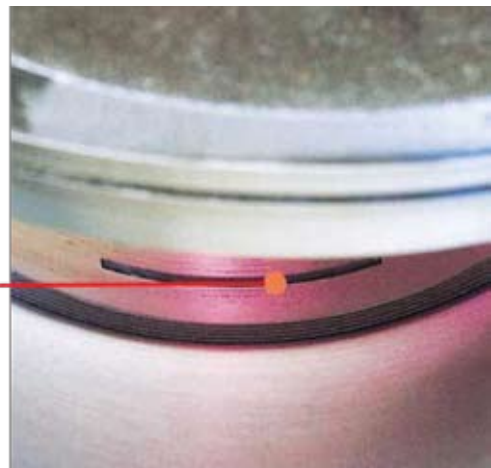

Any seepage through the first seal drains through hole between seals



Drain tap to check for leakage

Applications

As safety and environmental issues have become of greater concern to mankind, the need for assured valve shut off providing absolute and verifiable isolation are regularly becoming the standard specification for critical applications.

Typical areas of application include offshore and onshore petro-chemical production including gas injection, water injection, oil and gas transmission lines including airport fueling facilities and other areas where flammable and toxic emissions are unacceptable.

Design

Previous common practice has been to use two valves (fig1), such as plug or ball valve designs, in series with a bleed facility located between them in order to establish the sealing integrity of the upstream valve. This configuration is far from optimum as more space is required, with considerable extra weight quite apart from the additional maintenance requirements of having two valves and the extra associated costs.

The Solent & Pratt Double Block and Bleed design (fig3) utilizes our well established, patented triple offset segment valve (TOSV). Two seals are incorporated on the disc segment thus providing sequential sealing. The downstream seat is not spring loaded, as is the practice for trunnion mounted pipeline valves (fig2), which are also very heavy and expensive. Sealing integrity is therefore maintained should the upstream seat fail. When the valve is closed a channel between the two seats connects with a purge or bleed port in the valve body which is connected to an external outlet where an isolation valve or relief valve may be fitted for manual or automatic bleed. This compact Double Block and Bleed Design negates the need for reusing two valves in series

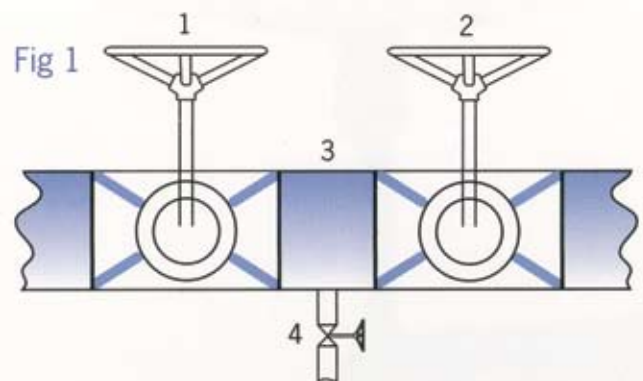

Conventional Double Block & Bleed installation. Two valves [1] and [2] plus spool piece [3] with bleed facility [4].

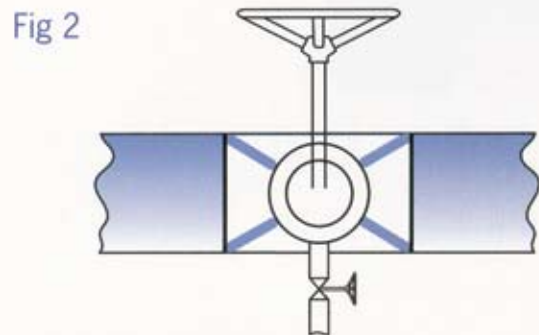

Single trunnion supported ball valve is a heavy and expensive option.

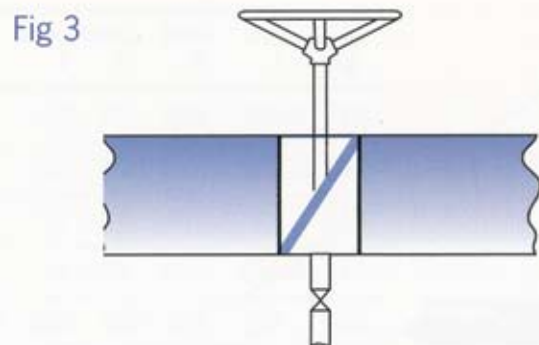

Double Block & Bleed TOSV saves space, weight and costs.

Double Block & Bleed

- Inherently Firesafe primary metal/metal sealing certified to API 607
- Shut off class API 598. Zero leakage shut off available in both directions.
- Replacement body seat and laminated disc seal.
- Triple offset Design (non-rubbing).
- Internal anti-blowout stem standard. External to API 609 optional.
- Materials of construction available to NACE requirements.
- Wafer, lugged, double flanged and butt weld ends available.
- ANSI 150, 300, 600, 900 & 1500 with fully rated trims.
- Quality Assurance Systems approved to ISO 9001
- Patented in UK with worldwide patents pending.

Body Styles

Wafer flangeless, lugged (through drilled and tapped), double flanged and top entry butt weld ended body style are available.

Flange Standards

All flange standards can be accommodated including ANSI, API, MSS, BS, PN and ISO.

Face To Face Dimensions

Face to face dimensions shown are to BS.5155. Options include ANSI B16.10 and API 6D. Non standard dimensions are available on request.

Operators

Valves can be supplied with manual, electric, pneumatic or hydraulic operators. Fail-safe systems for emergency operation are also available.

Materials

Carbon Steels, 316 St/St, Duplex St/St, 6MO St/St, Super Duplex, Bronze, Monel, Hastelloy B & C, Titanium, Zirconium, Incoloy.

Single Disc Design

Size/Ratings: 150lb 6" to 36", 300lb 6" to 36"
Temperature Range: -46 to +425 deg C

Twin Disc Design

Size/Ratings: 150lb 2" to 48", 300lb 2" to 48"
600lb 4" to 48", 900lb 6" to 36"
1500lb 6" to 24"
Temperature Range: -46 to +425 deg C

Triple Offset Segmented Valve (TOSV) Geometry

The shaft is offset in two directions. The disc is a segment taken from a cone where the apex is offset from the center line of the valve. No interference (rubbing) occurs between disc (segment) and seat making it ideal for metal seated valves.

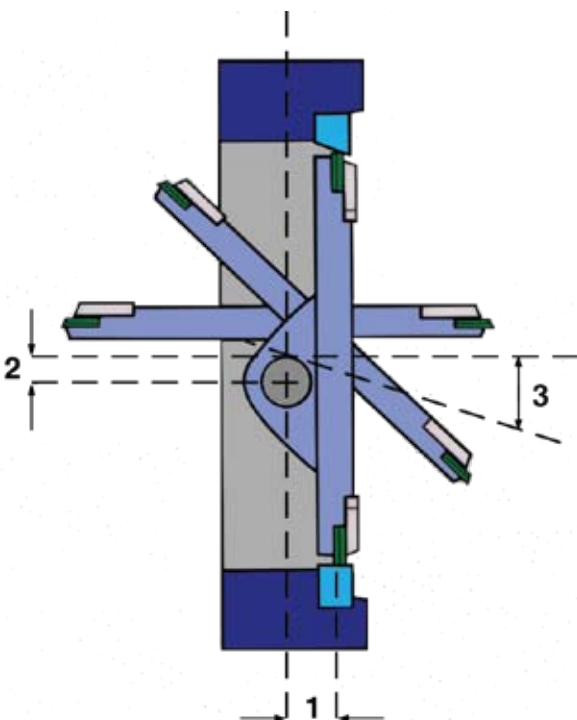

Double Block & Bleed

Typical single disc metal seated Double Block & Bleed TOSV envelope dimensions 6"

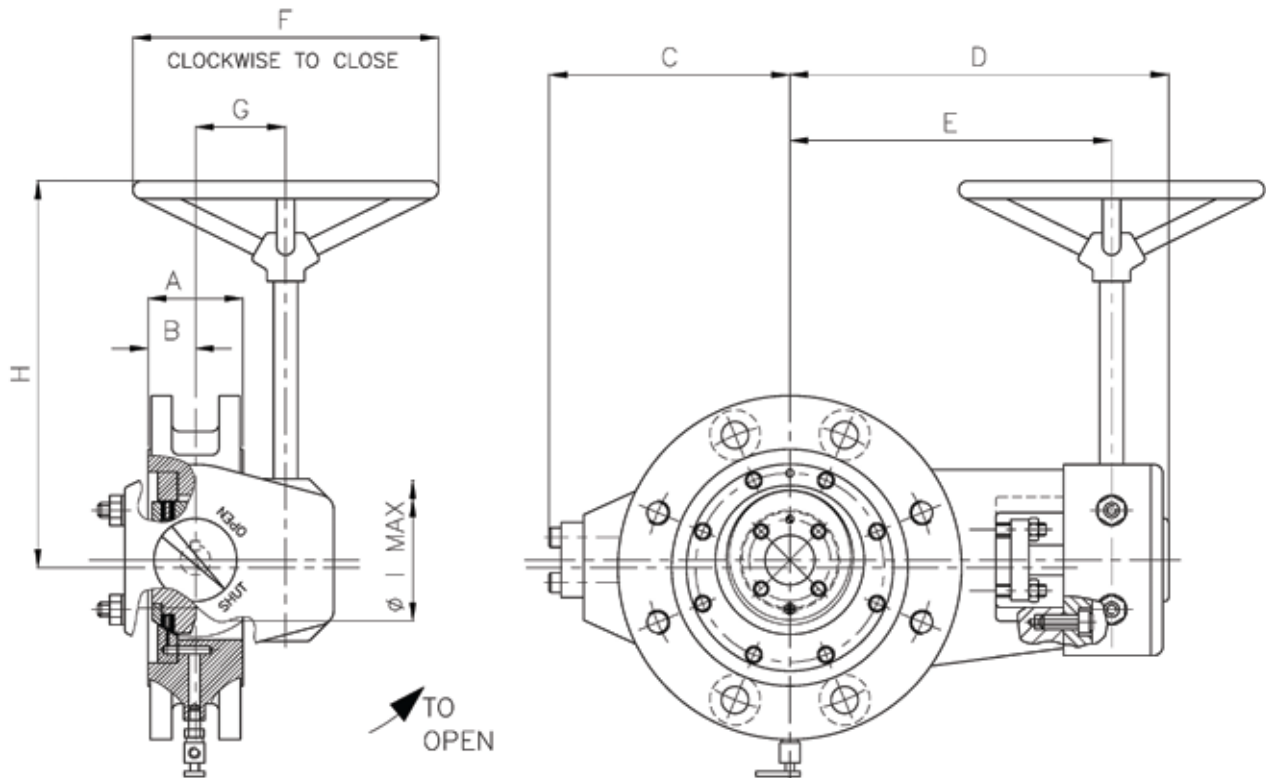

Class 150lb Range (dimensions in mm)

Valve Size Inches mm	Gearbox Size	Dim. A	Dim. B	Dim. C	Dim. D	Dim. E	Dim. F	Dim. G	Dim. H	Dim. I	Weight Kg
24 600	MJF50/S5/R24	267	133.5	470	705	610	610	97	526	496.6	725
20 500	MFF57/S3/R24	229	114.5	415	587	525	610	60	496	401.1	524
18 450	M16/R30	222	111	370	550.5	474	762	154	427	343.2	390
16 400	M15/R30	216	108	340	496	440	762	123	492	292.9	317
14 350	M14/R24	190	95	315	456	412.5	610	89.5	389	254	233
12 300	M14/18	178	89	285	421	337.5	457	89.5	329	271.5	190
10 250	M12/18	165	82.5	240	366	327	457	67	262	166.7	136
8 200	M12/R12	152	76	200	329	290	305	67	293	107.4	96
6 150	M10/R8	140	70	170	282	250	200	52	175.5	16.2	62

28" (700mm) to 84" (2100mm) refer to factory

Class 300lb Range (dimensions in mm)

Valve Size Inches mm	Gearbox Size	Dim. A	Dim. B	Dim. C	Dim. D	Dim. E	Dim. F	Dim. G	Dim. H	Dim. I	Weight Kg
24 600	MLF60/D12/R30	267	133.5	520	801	708	762	237	651	496.6	1120
20 500	MLF60/D12/R18	229	114.5	453	678	585	457	237	581	401.1	841
18 450	MJF30/S5/R24	222	111	408	641	564	610	97	525	343.2	649
16 400	MFF36/S5/R24	216	108	365	572	510	610	52	494	292.9	501
14 350	M16/R36	190	95	335	534	457	914	154	467	254	383
12 300	M15/R30	178	89	305	466	410	762	123	402	271.5	282
10 250	M15/R24	165	82.2	260	415	359	610	123	366	166.7	207
8 200	M14/R18	152	76	220	364	320.5	457	89.5	354	107.5	130
6 150	M12/R12	140	70	190	296	257	305	67	229.5	16.5	89

28" (700mm) to 84" (2100mm) refer to factory

Double Block & Bleed

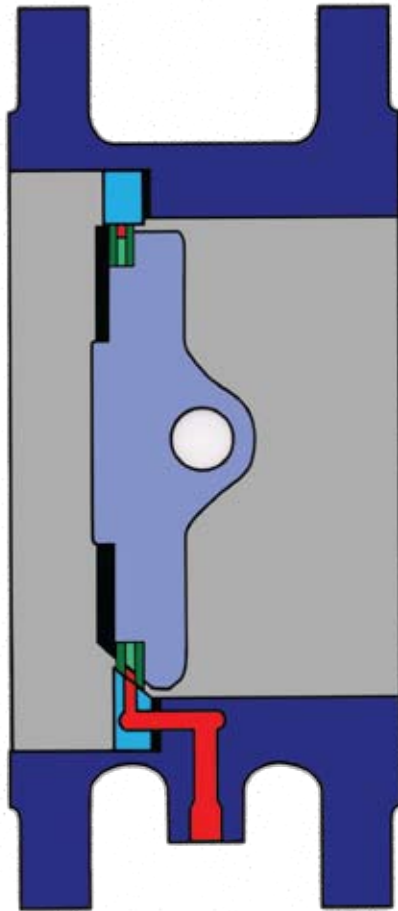

- Body
- Disc/segment
- Double Laminate Seals - replaceable
- Seal Retainer
- Seat Ring - replaceable
- Seal Spacer Ring
- Bleed Channel/Purge Port

Weight Comparisons

Description	Size	Weight (typical) ANSI 300lb	Number of Actuators for Automation
Solent & Pratt Double Block & Bleed TOSV	8" (200mm)	90kg 198lbs	1
2 Butterfly Valves & spool bleed piece	8" (200mm)	199kg 429lbs	2
Single trunnion Ball Valve with bleed facility	8" (200mm)	255kg 561lbs	1
Double Plug Valve, single body design	8" (200mm)	360kg 792lbs	2
2 Ball Valves in series and spool bleed piece	8" (200mm)	525kg 1115lbs	2

Twin Disc Design

The Twin Disc design of DBB butterfly valve can be used in many applications where weight is not a critical factor although the valve is up to 25% lighter than a comparable through conduit gate valve with bleed arrangement or where health and safety legislation or local regulations call for a true double isolation on such applications as Steam Lines, Toxic Fluids and other hazardous fluids, the valve gives unparalleled protection to personnel working downstream of the valve. The valve can be supplied with either manual or actuated options utilising most pneumatic, electric & hydraulic actuators. This valve can also be supplied in ratings of up to 1500lb with a true 255bar (1370 psi) shut off capability.

Double Block & Bleed

Typical twin disc metal seated Double Block & Bleed TOSV envelope dimensions 8"

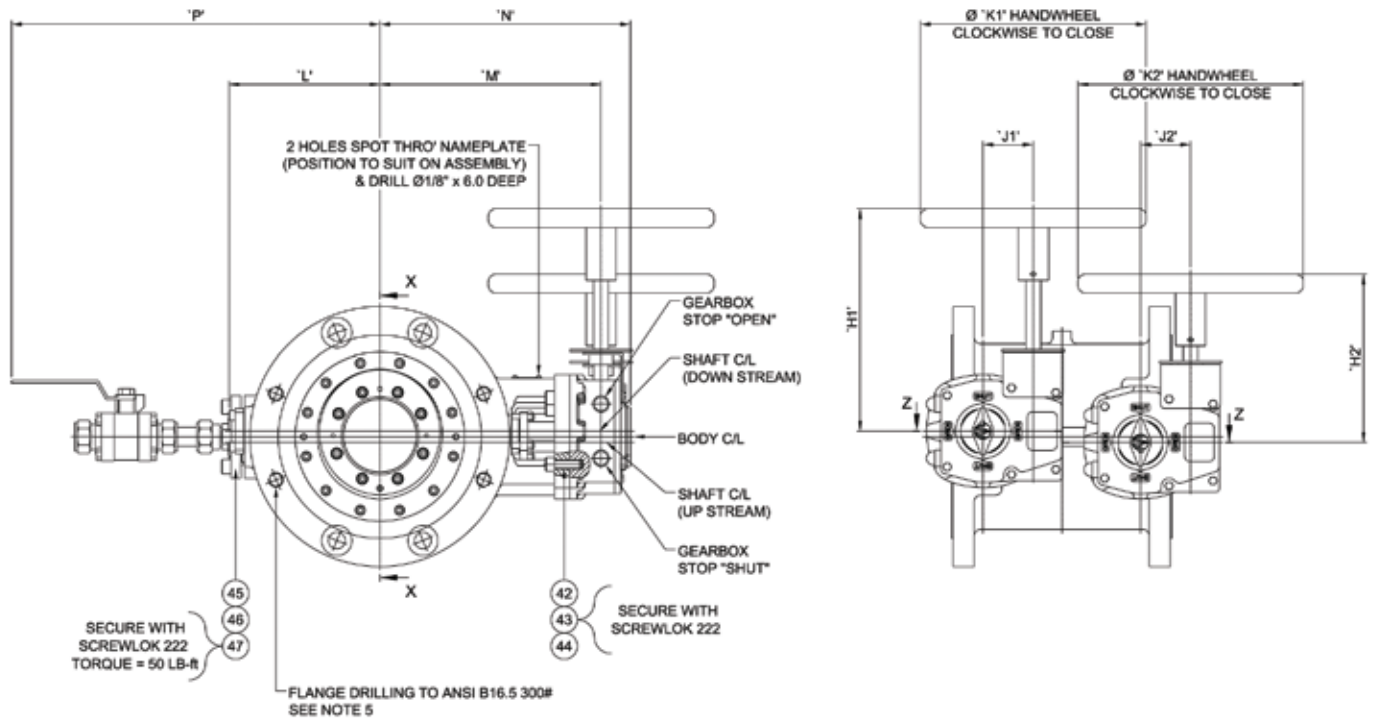

While this information is presented in good faith and believed to be accurate, Solent & Pratt, A Division of Curtiss-Wright Flow Control (UK) Ltd., does not guarantee satisfactory results from reliance on such information. Nothing contained herein is to be construed as a warranty or guarantee, expressed or implied, regarding the performance, merchantability, fitness or any other matter with respect to the products, nor as a recommendation to use any product or process in conflict with patent. Solent & Pratt, A Division of Curtiss-Wright Flow Control (UK) Ltd., reserves the right, without notice, to alter or improve the designs or specifications of the products described herein.



Curtiss Wright Flow Control UK Ltd
Napoleon House, Corbin Way
Gore Cross Business Park
Bridport, Dorset, DT6 3UX
United Kingdom

Tel: +44 (0)1308 422256

Fax: +44 (0)1308 427760

Email: salespp@curtisswright.com

<http://solentpratt.cwfc.com>