

# SchuF Fetterolf Drain & Sampling Valves ABLASS- UND PROBENAHMEVENTILE



# Company Profile

*“Every SchuF valve is an innovation in itself”*

Wolfgang Frank  
Chairman, SchuF Fetterolf Group

For over 100 years SchuF valves have stood for innovation and quality at the highest level.

Together with our customers, we invent, design and manufacture valves customised to exact tolerances, processes or special operating conditions. SchuF Fetterolf valves can be found in standard and in many severe service applications in the Chemical, Polymer, Pharma, Oil, Gas, Offshore and Refining industries.

## ... Innovation

The invention of the Lift Plug valve in 1911 and piston & disc bottom outlet valves in the nineteen twenties by the founder of SchuF – Josef Frank – were the first of a long line of valve inventions and innovative designs. Continuing research and development in materials (used in valve bodies and trim), design as well as complex processes enable SchuF today to offer valve solutions for applications with high pressure, high temperature and difficult media; or a combination of all three.

The integration of Fetterolf Corporation in 2004 further broadened the Group’s product portfolio, innovation and geographical reach. Today the SchuF Fetterolf product line includes control, isolation, sampling, switching and safety related valves.

## ... Quality

The exceptional quality and longevity of SchuF Fetterolf valves is a result of the precise attention to process detail, creative design, and the use of the appropriate high quality materials. In addition to its own high internal company standards, SchuF is ISO 9001, GOST and PED certified and can manufacture according to ASME, DIN, NACE, API, Fire Safe, GMP, JIS or any other internationally recognised standard.

## ... Worldwide presence

SchuF Fetterolf is represented in over 65 countries worldwide and has design and production facilities in Germany, Ireland, India, Brazil, the United States and the United Kingdom.



## Bottom Outlet and Drain Valves

SchuF invented the first industrial class bottom outlet valve 100 years ago. Today SchuF Fetterolf offers tank bottom valves with a disc or piston design in almost any material, pressure class or size and with many options.

### Disc Bottom Outlet Valves (DBOV) – Model 18 / 19 / 24 / 25

#### Application:

Disc bottom outlet valves are commonly used in Pharmaceutical and Fine Chemical processes to drain or feed non-viscous media from vessels or reactors. Reactor considerations such as the position of internal mixing equipment and the nature of the media determine the need to use a disc lowering or disc rising valve variant.

An additional benefit of the latter is that the formation of crust is automatically removed when the disc is moved to the open position.

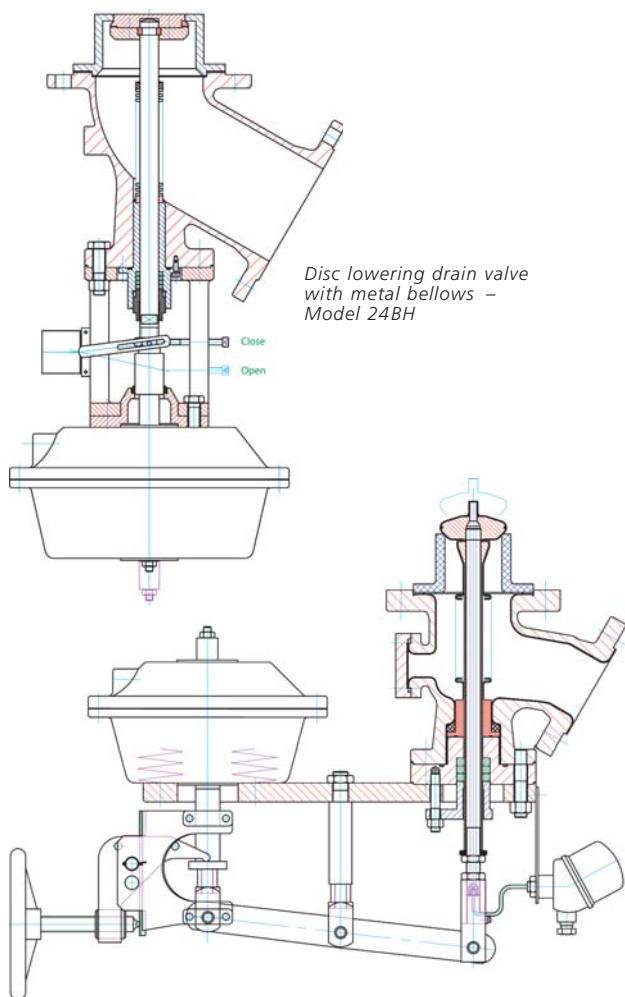

Disc rising drain valve with side actuation – Model 25BF

### Key Advantages for Disc and

#### ■ Compact Valve Build

A short stroke disc valve is ideal where space is limited or weight is a concern. Smaller, lighter and faster actuators can be used.

#### ■ Dead Space Free

SchuF drain valves are designed to ensure that the vessel and the valve itself drain completely. There are no spaces for matter to accumulate.

#### ■ Crust Breaking

For media containing crystals or crust forming substances, certain ram and disc valves offer the ability to clear any blockage and ensure problem free flow.

#### ■ Zero Emissions to Atmosphere

Disc valves can be fitted with a metal or PTFE extruded bellows or a PTFE Diaphragm. Leakage of toxic or flammable substances are eliminated.

All Disc and Ram valves are available in sizes from 1" (DN25 standard). The outlet angle can be 45°, 60° or 90°. Custom are available on request.

#### Options

- Fire Safe design
- CIP (Clean in Place)
- Temperature sensing
- Wide choice of material
- GMP designs
- PTFE or glass lining
- Heating jackets
- Disc grinding
- Flushing connections
- Leak detection



# Bottom Outlet and Drain Valves

Flush bottom outlet valves can also be used for feeding, injection or sampling applications. Special designs are available for critical processes or media such as slurries. SchuF valves are customised to meet your exact equipment or process needs.

### Piston Bottom Outlet Valves

- Fast Draining**  
 Full bore unimpeded flow piston valves are ideal to quickly drain reactors, tanks or pipelines.
- Diverse Sealing Options**  
 Metal to metal or soft seal in the valve body, vessel or with an extended sleeve ensure the right sealing characteristics for different process requirements. Please see page 6.
- Super Closure**  
 Super Closure is a self adjusting mechanism, that ensures a constant bubble tight seal to atmosphere.
- Customised Design**  
 Every SchuF valve can be customised to match the exact specification of the vessel, reactor or tank. Material and instrumentation can also be customised for specific plant requirement.
- Replaceable Valve Seat**  
 The ability to easily change the customised valve seat reduces down-time and saves money.



Ram drain valve – Model 26FR

### Ram Bottom Outlet Valves (RBOV) – Model 26 / 28

#### Application:

Piston bottom outlet valves are used to quickly drain or feed vessels or reactors. They are normally full bore. For these reasons piston BOVs are favoured for processes with viscous media. They clean the valve body with each piston stroke and optionally can clear crust or scale around the vessel outlet.

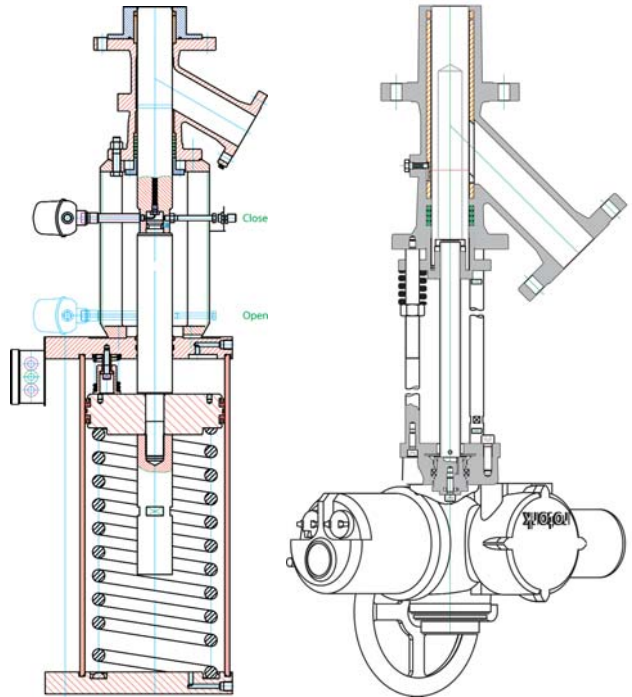

Ram drain valve – Model 28KR

Rod Seal drain valve – Model 26FR

to 24" (DN600) and up to ASME 2500# pressure class as standard design, larger nominal bore and higher pressure classes

- High corrosion resistant coatings
- Full automatic control
- Internal/External polishing
- Hard facings
- Contoured pistons
- Position and safety sensors
- Manual, pneumatic, hydraulic or electric actuation

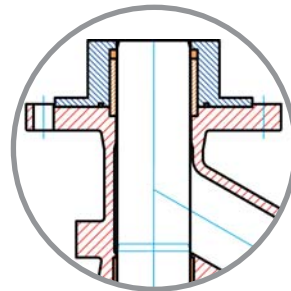

Detail: Soft Seal in the vessel

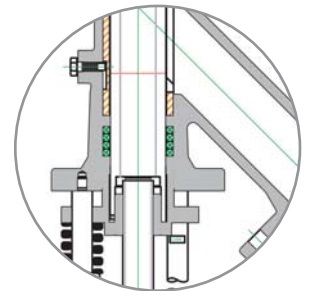

Detail: 26FR – Super Closure

# Bottom Outlet and Drain Valves

## Flush Bottom Outlet Valve Examples

### Hydraulic Actuated Disc Valve – Model 25BH

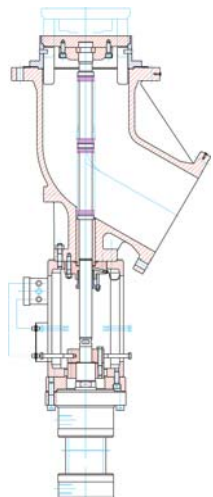

#### Features & Benefits:

- Powerful space saving hydraulic actuation
- Rising disc with automatic crust breaking
- Metal bellow seal for zero emissions
- Ideal for higher pressure or temperature applications

### Short Stroke Ram Valve – Model 28KS

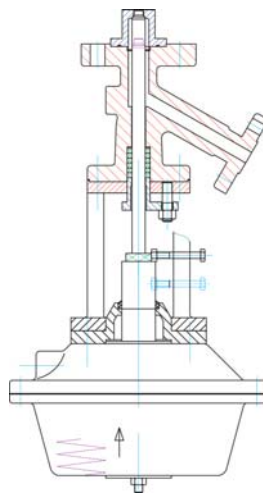

#### Features & Benefits:

- Short stroke valve with pneumatic actuation
- Ideal where space is limited but fast draining and injection is required

## Sealing Method Options

### Custom Fit Seat Sealing Options

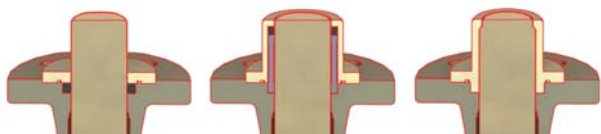

**Model 28KV**  
Radial soft seal in the valve body

**Model 28KR**  
Radial soft seal in the vessel

**Model 28KS**  
Metal seal in the vessel

### Integrated Seat Sealing Options



**Model 28FX**  
Extended plunger

**Model 28FS**  
Extended body

**Model 26FR**  
Extended body with a radial seal

### MultiProbe® Valve – Model 25BF



#### Features & Benefits:

- Infrared (IR) reaction monitoring for Process Analytical Technology (PAT) applications
- Integral IR and temperature sensor in one stem and disc
- Equipped with a unique and patented sealing system

### Disc Lowering Valve with Diaphragm – Model 24BM

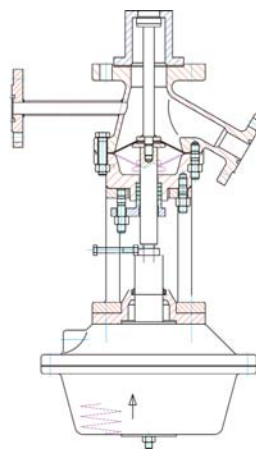

#### Features & Benefits:

- Zero leakage to atmosphere with diaphragm inside the valve body
- Flushing connection for in service cleaning
- Typically used in Pharmaceutical applications

A full brochure is available at: [www.schuf.com/pdf](http://www.schuf.com/pdf)

# Sampling Valves

## Sampling Valves

Many chemical and pharmaceutical processes need to be regularly tested during processing to ensure consistent product quality. SchuF Fetterolf sampling valves enable trouble free and safe content sampling of pipelines, reactors, tanks and storage vessels without product loss or cross contamination.

### Product Range

#### Screw-in Sampling Valves – Model 32

- Screw-in or flanged to pipelines, reactors or vessels
- Size up to 1½" and ASME 600#
- Available with different flange and seat options
- Materials: carbon steel, stainless steel and most alloys
- Diverse sealing options include:
  - Metal Seated Ram (32PG)
  - Metal Seated Disc (32PT)
  - Ram PTFE Seal Rings (32FR)
  - Metal Seated Ram with PTFE (32FG)



#### Core Pipe Assembly – Model 30

- Sampling valve with an integral core pipe assembly & heating jacket
- Sampling under high temperature and pressure up to ASME 2500#
- Vertical or horizontal installation
- Contoured ram options
- Customised assemblies to match your exact sampling requirements



A full brochure is available at:  
[www.schuf.com/pdf](http://www.schuf.com/pdf)

#### Wafer Sampling Valves – Model 31

- Sampling valve with integral flange insert
- Flange insert is installed into the product line
- Insert size up to 12" and ASME 600#
- Available with any Model 32 sealing options



#### Key Features:

- Robust construction for longer valve life
- Dead space free, non clogging design
- Class V or VI shut-off
- Standard designs are stocked, customised design on demand
- Heating jacket and optional outlet legs
- Fire safe design according to BS 6755 Pt.2

#### Customised sampling systems for many applications such as:

- Fixed volume sampling under high pressure and temperature
- Sampling with zero leakage to the atmosphere
- Wet or dry powder sampling
- Visual checks through sight glasses



# Product Portfolio Overview

SchuF Fetterolf has delivered over one million valves during its 100 year history to a wide variety of industries in over 50 countries worldwide.

Headquartered near Frankfurt in Germany, the company has additional design and manufacturing centres in Brazil, India, Ireland, UK and the USA.

The SchuF group has sales and agent offices covering almost every country in the world.

We manufacture valve products that control, isolate, divert, and sample liquids, gases, powders, and slurries. Our product range of engineered, customised valves includes:

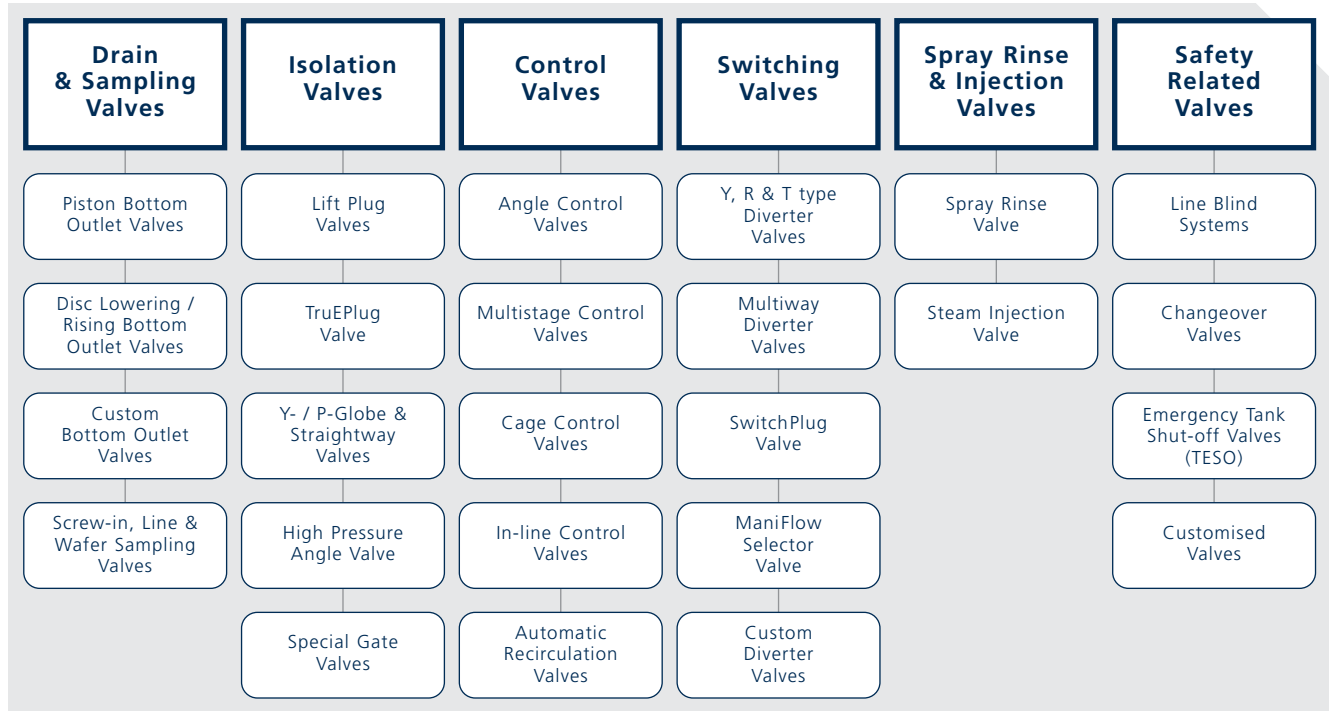

## Key Client List:

- |                  |                     |                  |
|------------------|---------------------|------------------|
| ■ AkzoNobel      | ■ Glaxo Smith Kline | ■ Reliance       |
| ■ AstraZeneca    | ■ INEOS             | ■ Roche          |
| ■ BASF           | ■ Invista           | ■ SABIC          |
| ■ Bayer          | ■ Jiangsu Hengli    | ■ Saipem         |
| ■ BP             | ■ Lanxess           | ■ Salavat        |
| ■ Chevron        | ■ LG Chemical       | ■ Samsung        |
| ■ Clariant       | ■ Linde             | ■ Sandoz         |
| ■ DOW Chemical   | ■ Lukoil            | ■ Sanofi Aventis |
| ■ Du Pont        | ■ Lurgi             | ■ Shell          |
| ■ Eastman        | ■ Merck             | ■ Shin Etsu      |
| ■ Evonik         | ■ Novartis          | ■ Sinopec        |
| ■ Exxon Chemical | ■ Oerlikon          | ■ Sulzer         |
| ■ FCFC           | ■ Oxy Vinyls        | ■ Temex          |
| ■ Far Eastern    | ■ Pemex             | ■ Tuntex         |
| ■ Foster Wheeler | ■ Petrobras         | ■ Uhde           |
| ■ GE             | ■ Pfizer            | ■ Vinnolit       |



# SchuF Worldwide

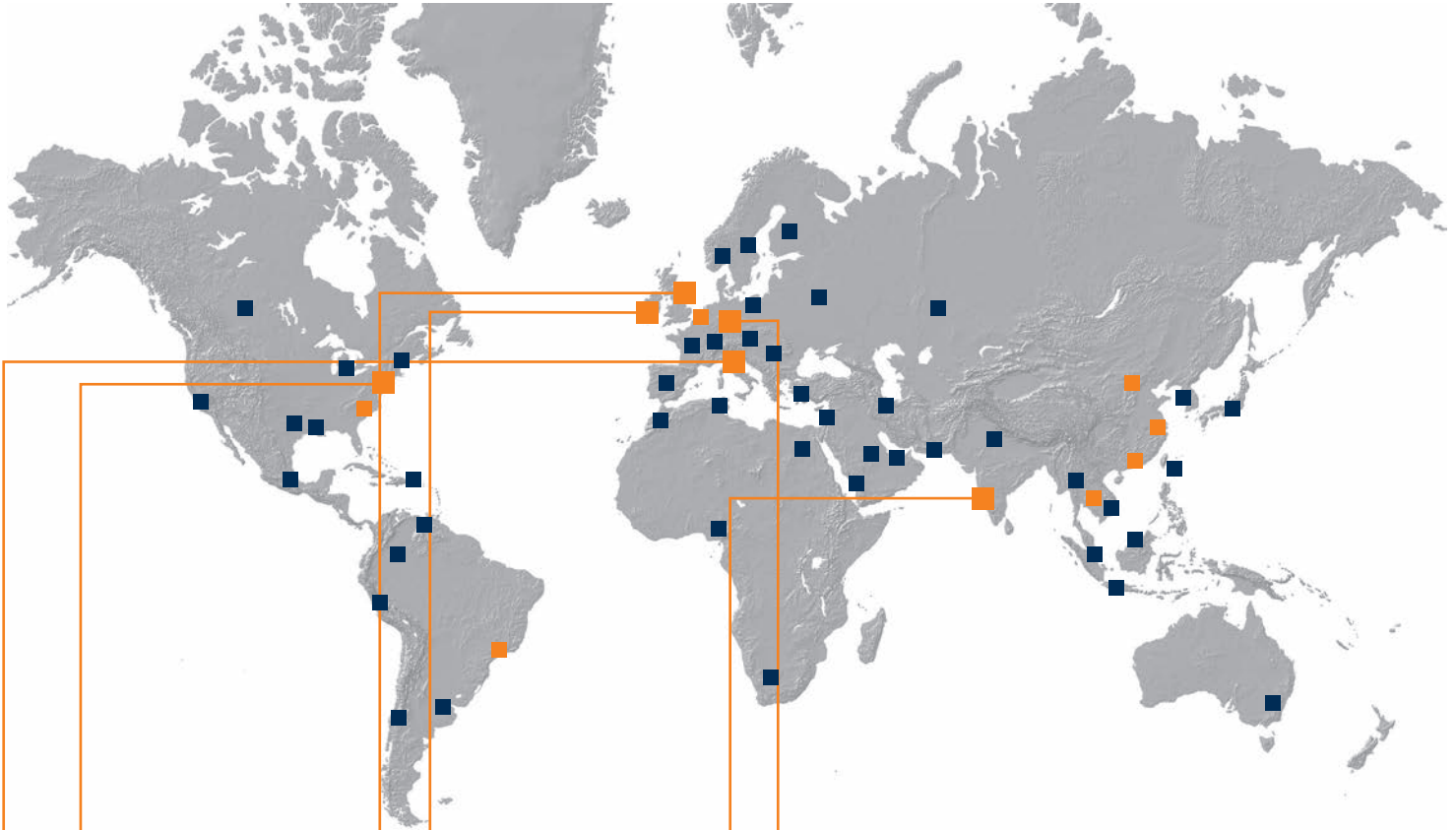

[www.schuf.com](http://www.schuf.com)

[www.schuf.de](http://www.schuf.de)

## USA



**Fetterolf Corporation**  
phone: +1 610 584-1500  
info@fetterolfvalves.com

**SchuF (USA) Inc.**  
phone: +1 843 8813345  
sales@schuf.us

## IRELAND



**SchuF Valve Technology GmbH**  
phone: +353 (0)21 4837000  
sales@schuf.ie

## GERMANY



**SchuF Chemieventile  
Vertriebs GmbH & Co.KG**  
phone: +49 (0)6198 571 100  
verkauf@schuf.de

## Your Sales Channel:

**SchuF Benelux B.V.**  
phone +31 25 12 34 448  
lieke@schuf.nl

**Emartins Armaturen – ME**  
phone: +55 19 98013503  
emartins@schuf.com

**SchuF South East Asia Pte. Ltd.**  
phone +31 62062 6664  
marius@schuf.nl

**SchuF Valves China Ltd.**  
phone +85 22 86 50 86 1  
see@vol.net

## ITALY



**La Tecnovalvo S.r.l.**  
phone: +39 023503508  
info@latecnovalvo.com

## UNITED KINGDOM



**SchuF (UK) Ltd.**  
phone: +44 203 355 2012  
sales@schuf.co.uk

## INDIA



**SchuF Speciality Valves  
India Pvt. Ltd.**  
phone: +91 421 2264600  
sales@schuf-india.com

## Your Local Agent: